

Antenna (63A/63AA) Installation Guide

天线(63A/63AA)安装说明



Issue: 01
文档版本: 01

NOTE/说明

1, Only qualified personnel are allowed to install the antenna.

1, 天线的安装需由合格的安装人员操作。

2, Appearance of the actual antenna may differ from the pictures.

2, 部分图示与实物可能稍有差别, 具体情况请以实物为准。

Installation tools

安装工具



Bracket Subassembly

支架组件

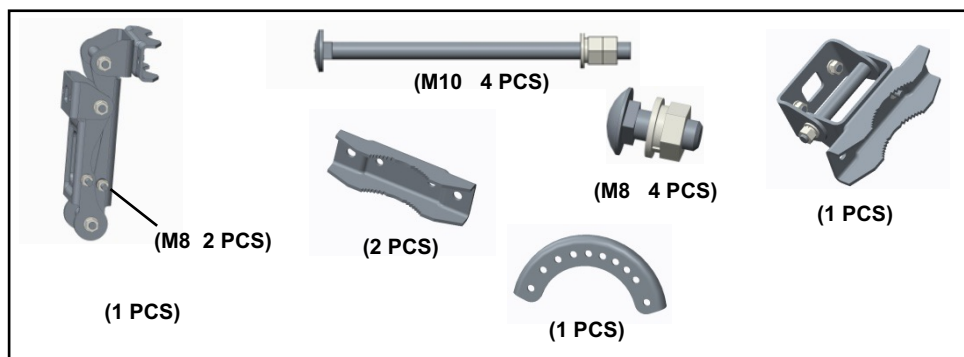

1 Install the bracket

安装支架

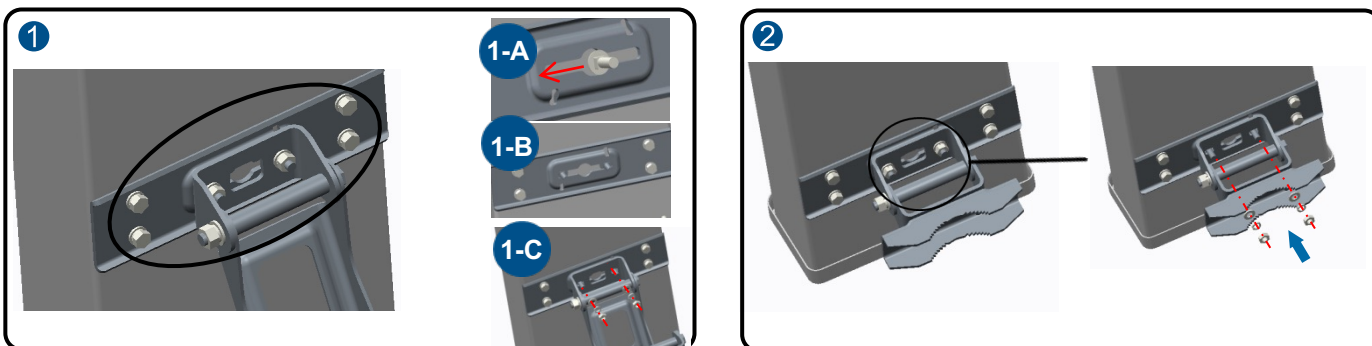

2 Install the antenna

安装天线

Ensure the upper bracket is fully closed before the bolts are screwed tightly.
在拧紧抱杆螺丝之前确保上安装臂完全折起。

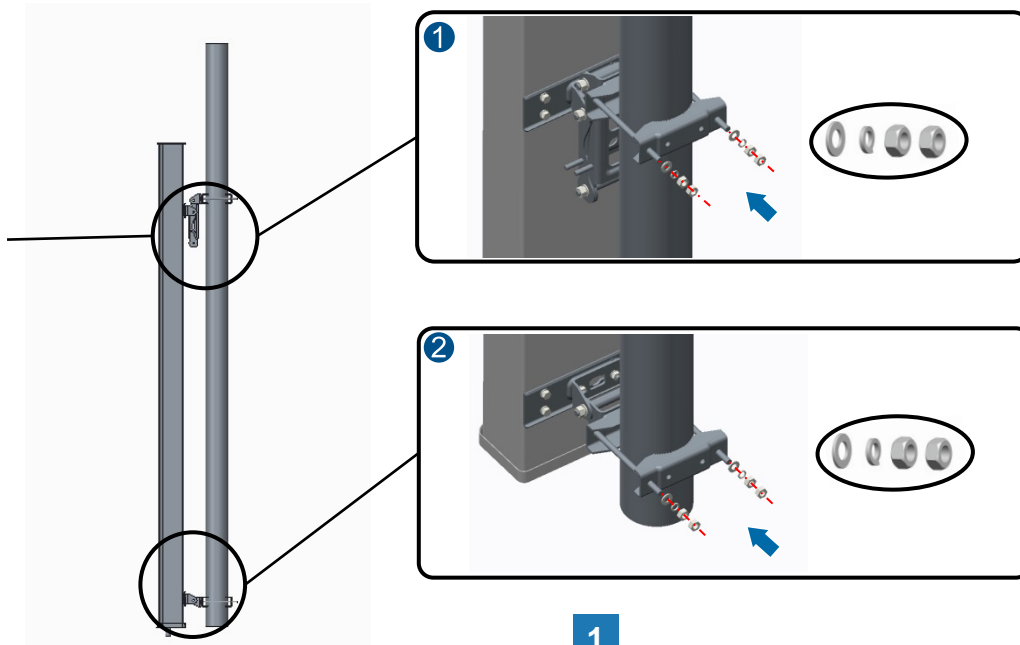

3 Install the Scale 刻度片安装

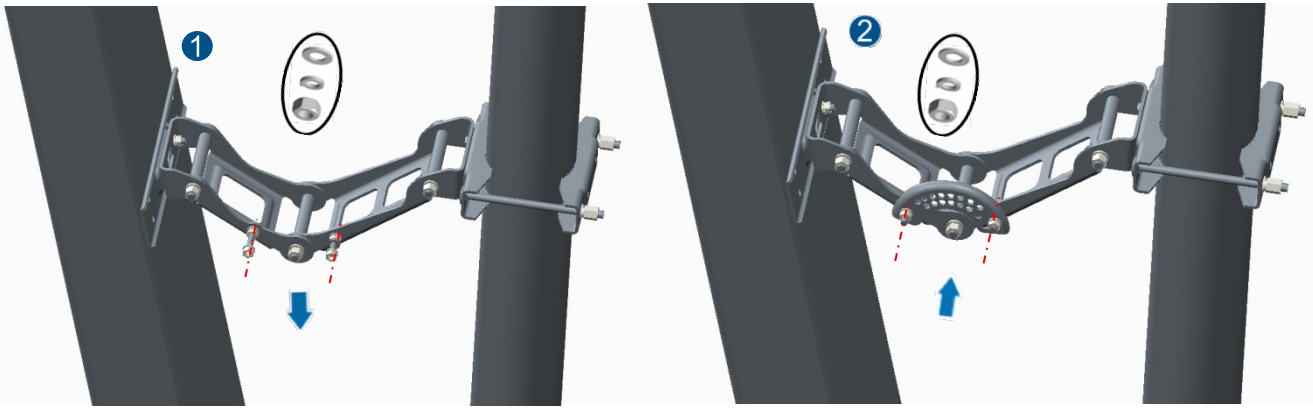

4 Adjust the mechanical downtilt angle 调节机械下倾角

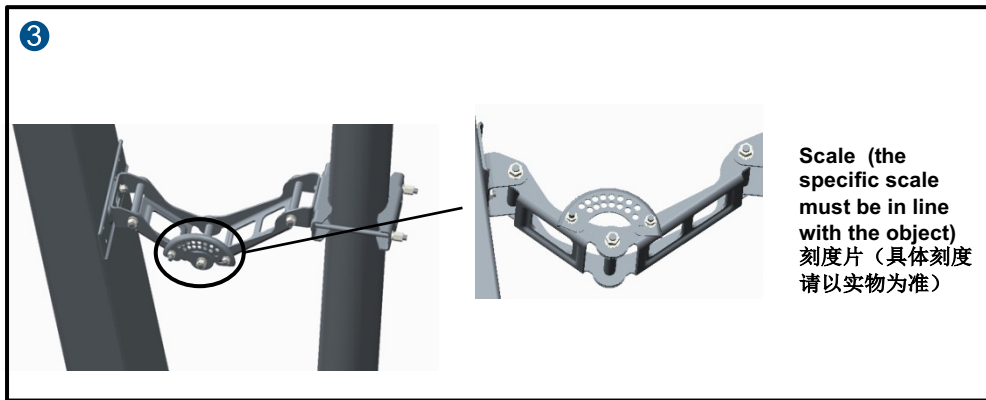
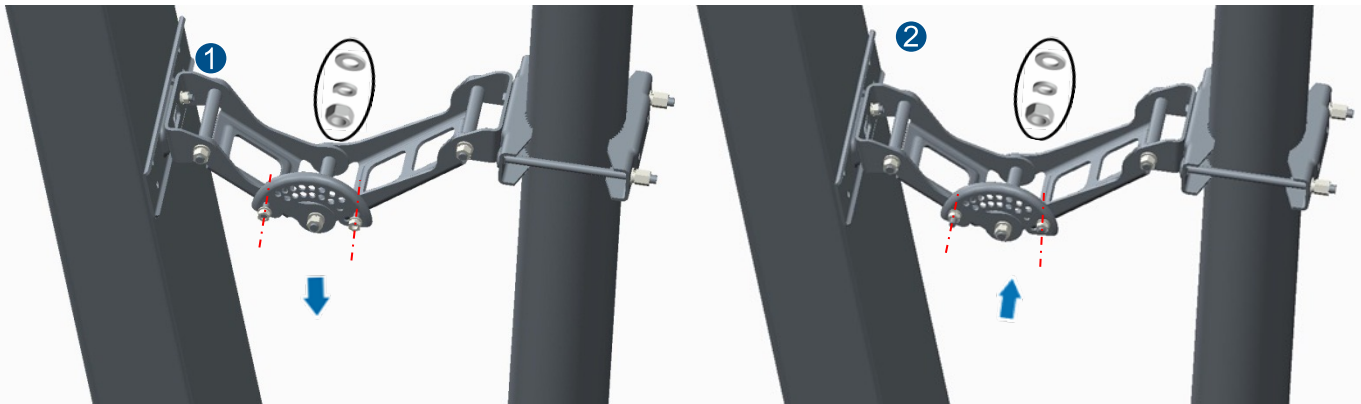
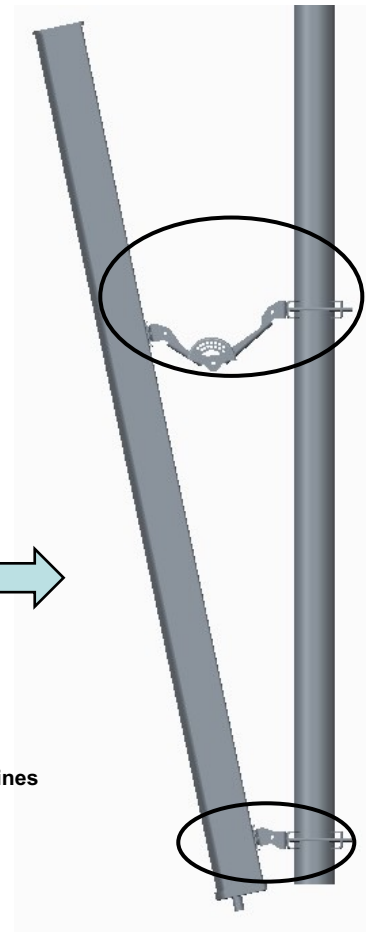

Table 1/表 1

Finally, tighten all the nuts. Recommended torque see Table 1.

最后拧紧所有螺母。参考扭矩如表1所示。

Screws size/螺钉尺寸	Torque/力矩
M8	18 Nm
M10	32 Nm



Note/注意:

Make sure the antenna is installed in a safe and suitable location and well clear away from high power lines
 天线安装时, 要选择一个远离高压的安全点进行安装
 Do not attempt to carry out installation when it is raining, snowing or during stormy weather
 严禁在下雨、下雪或刮大风等天气恶劣的时候安装天线
 Do not attempt to install the antenna on a pole of diameter other than the specified 50~115mm
 选择合适的抱杆, 严禁使用直径为50~115mm之外的抱杆

For particular installation, please contact Tongyu Communication Inc.
 如需特殊安装请联系 广东通宇通讯股份有限公司, 网址: www.tycc.cn